

**DEVELOPMENT SERVICES – BUILDING INSPECTION****INSPECTION GUIDELINES:
TEMPORARY ELECTRICAL POWER – RESIDENTIAL****INSPECTION CODE:** 202, 246**SCOPE:** RESIDENTIAL**APPLICABLE CODES:** 2016 CBC, CRC, CPC, CMC, CEC, CALGreen, CEnC, and PAMC

The information provided in this document is general and intended as a guide only. Each project is unique and additional requirements may be enforced as deemed appropriate.

WARNING

Meter removal and service disconnect/reconnect are to be performed by City of Palo Alto Utilities (CPAU) personnel only. Contractors who tamper with CPAU equipment will be issued a citation. Citations will be assessed at \$500.00 per incident. (PAMC 12.20.01.0)

Failure to complete the items below prior to inspection may result in a re-inspection fee.

For additional information, see the “Temporary Power – Residential Submittal” checklist under the Electrical Inspection Guidelines in the [City of Palo Alto Building Inspection](#) website.

DEFINITIONS

Construction Power: Electrical power used for construction power utilizing the existing permanent power or new permanent power. This is NOT a temporary power pole application. (This method must comply with Title 8 and the California Electrical Code.)

Temporary Power: Underground or overhead temporary power pole or pedestal. (This method must comply with Title 8 Article 33 and the California Electrical Code.)

INSPECTION

- If the Contractor converted or used the existing electrical service for construction power, make sure that the requirements for converting/using the existing electrical service have been met (see the “Construction Power – Residential Submittal” checklist for more information under the Electrical Inspection Guidelines in the [City of Palo Alto Building Inspection](#) website).
- If temporary power is an underground service, make sure that the green sticker has been applied to the panel by CPAU.
- All underground conduits shall be sealed with duct seal or approved methods. Sealants must be identified for that use. (CEC 300.5 (G), CEC 230.8)
- Verify that the terminals for fine stranded conductors must be listed for that use. (CEC 110.14)

- Provide required working clearance in front of equipment. For a panel, the minimum working clearance is 36" in depth, 30" in width, and maximum 6'-6" in height. (CEC 110.26)
- For overhead service conductors, provide minimum clearance to grade. A minimum clearance of 12' is required over property and driveways. (CEC 230.24 (B)(1))
- Verify the following requirements for overhead poles. ([CPAU Standard Drawing SR-TS-O-1006](#))
 - Pole must be 6"x6"x20' (minimum size) and set into the earth a minimum of 4' deep.
 - Provide two braces installed at 4' from the top of the pole and a distance of 8' from the bottom of the pole.
 - The braces must be bolted to a 2"x4" stake, and the stake must be set 3' into the earth.
 - Contractor is allowed to provide an alternate bracing. Provide a guy cable ¼" minimum in thickness with a minimum capacity of 10,000 lbs. The guy cable must be galvanized steel and have a strain insulator, anchor, and fittings.
- CEC 406.9(B): Outlet Box Hoods (While-In-Use)
 - Receptacles of 15A and 20A in wet locations shall have an enclosure that is waterproof. The outlet box hood (While-In-Use) shall be listed and shall be identified as "extra duty."
- GFCI protection is required at all outlets for temporary and construction power. (CEC 590.6 (A), CEC 590.6 (B))
- Apply anti-corrosion grease or oxidation inhibitor on all service entrance conductors terminating at mechanical lugs. (CEC 110.3 (B))
- Install exterior-rated ground clamps at all exterior locations (all bronze clamps, including the screws). !
- Panel box must be clean and free of debris. i
- Verify grounding electrode conductor and the connection to grounding electrode are not subject to physical damage. (CEC 250.64(B))
- Provide the following clearances on panel height. ([CPAU Standard Drawing SR-TS-O-1006](#))
 - 48" minimum from grade
 - 75" maximum from grade
 - 6'-7" maximum height (from grade to top of handle in its highest position) for a disconnecting means. CEC 404.8(A)

- Utilize any of the following allowed conduits for entrance service conductors with positive attachments to pole as required. ([CPAU Standard Drawing SR-TS-O-1006](#))
 - Rigid galvanized steel
 - EMT
 - PVC Schedule 80 if subject to physical damage
 - PVC Schedule 40 if not subject to physical damage
- For overhead service, provide a minimum 24" long insulated wire drip loop extension from the weather-head. ([CPAU Standard Drawing SR-TS-O-1006](#))
- Provide one ground rod that is at least 5/8" by 8'. ([CPAU Standard Drawing SR-TS-O-1006](#), CEC 250.52 (A)(5))
- Comply with all applicable requirements found in [CEC Article 590](#) for Temporary Installations.
- Where electrical equipment is subject to vehicular traffic, provide bollards. ([CPAU Standard Drawing SR-MT-E-1035](#))
 - Note that water-filled barrier may be allowed in certain conditions; check with your CPA inspector prior to their use.

UNDERGROUND SERVICE

- For underground electrical services, the Contractor must call CPAU at (650) 496-6977 to schedule an inspection with CPAU before entering a CPAU electrical vault. CPAU will inspect and shall place a green sticker on the panel prior to the Building Department Inspection.
- ONLY qualified CPAU Electric Personnel shall enter vaults and boxes, connect/disconnect/reconnect electric services, and/or remove/install electric meter. Contractors who tamper with CPAU equipment will be issued a citation. Citations will be assessed at \$500.00 per incident. (PAMC 12.20.010)
- Install underground conduit to permanent power location prior to all-trades inspection (see Figure CPA 002).

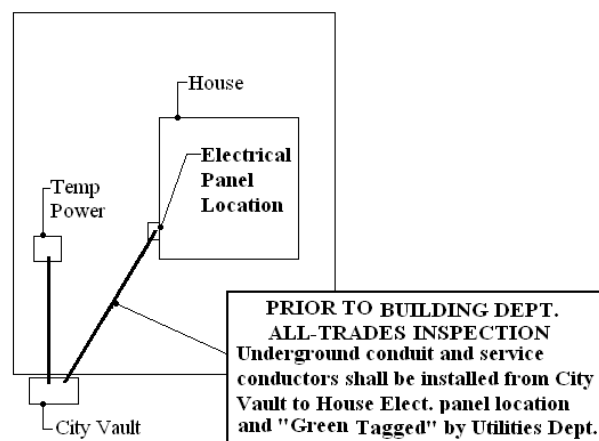

Figure CPA 002 – Underground Service Requirements (Temporary and Permanent Installations)

- All underground conduits shall be sealed with duct seal. Sealants must be identified for that use. (CEC 300.5 (G), CEC 230.8)

TORQUE REQUIREMENTS

- Verify and torque service conductor lugs and all connections to manufacturer’s specifications. Torque will be verified for all electrical panels – including construction trailers electrical panels.
- Contractor to provide a written list of torque specifications on site for the inspection specific to each piece of electrical equipment, including: circuit breakers, equipment grounds, neutrals, and feeders.
- Contractor to torque all connections per the manufacturer’s listings prior to the CPA inspection. The inspector will witness a spot check. If all terminations are found to be tight, no further torquing will be required. If loose connections are found, all connections will be required to be torqued in front of the CPA inspector.
- The electrical contractor must be on site with the following tools. (CEC 100.3 (b))
 - Torque wrench
 - Torque screwdriver (with a range of up to 50 lb-in.) and be audible type (ratcheting)
 - Slip-joint pliers such as Channel locks to secure lugs in place when applying the proper torque

ELECTRIC VEHICLE SUPPLY EQUIPMENT (EVSE) CONNECTION POINT

- If the Contractor is using the Electric Vehicle Supply Equipment (EVSE) as a connection point for feeding the main service for a temporary power source during construction, verify the following:
 - A 30A, 40A, or 50A receptacle is located at the main electrical panel (see Figure CPA 003)
 - A “while-in-use” type receptacle is installed for any exterior locations
 - The panel is identified with a label that reads “CAUTION: CURRENTLY BEING BACKFED BY ANOTHER SOURCE.”
 - The main breaker must be turned off, locked out, and tagged out by a qualified person when the service is fed from temporary power.

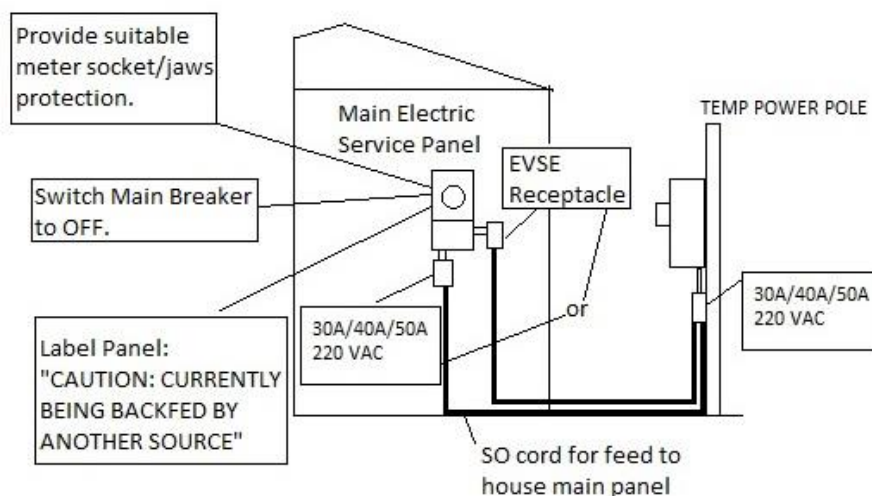

Figure CPA 003 – Feeding Structure from Temporary Power

PANEL CONNECTIONS

- See Figure CPA 011 for suggested connections to panels when using fine-stranded conductors.

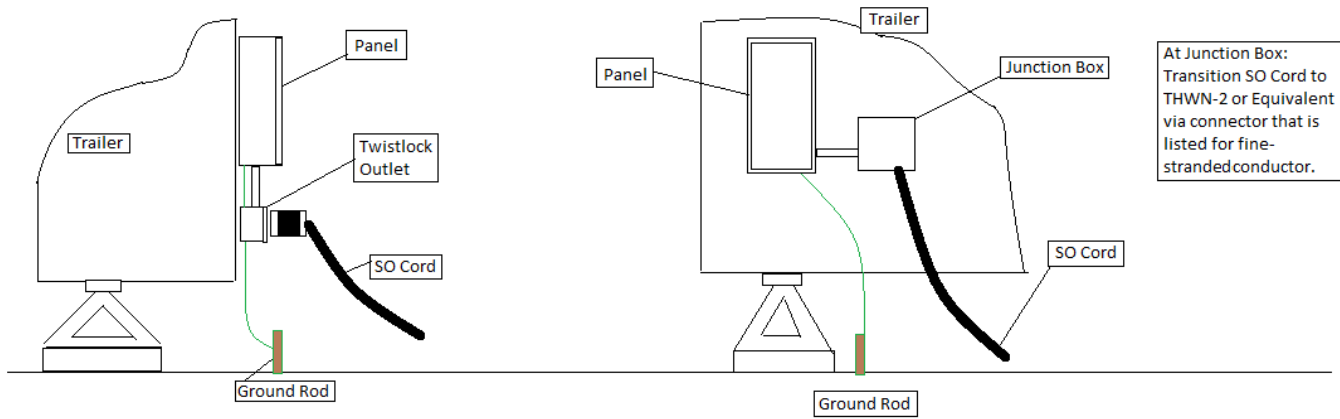

Figure CPA 011 – Suggested Connections to Panels when using Fine-Stranded Conductors